



PA700 Measurement Power Amplifier

Features:

- High performance measurement power amplifier based on class-D amplifier technology
- Peak output power up to 710 W at 1% THD+N into 4 Ω
- THD+N \leq 0.5 % (95 % power, 1 kHz, 4 Ω / 8 Ω)
- Frequency response 20 Hz~20 kHz
- 112 dB dynamic range (A-weighting, 1kHz, 4 Ω)
- Total power efficiency 74 %~84 %
- Universal mains 100-240 VAC 50-60 Hz
- Wireless remote control and Bluetooth audio receiver
- Built-in white noise, pink noise generator
- Overload, over-current, loop saturation, thermal and high-frequency protection
- Lightweight and portable



Applications:

- Driving medium and high power sound source for building acoustic
- Reverberation time measurement, transfer path analysis
- Sound insulation measurement, absorption coefficient measurement

Introduction

PA700 is the measurement power amplifier developed by BSWA for drive mid-power sound source, such as omni sound source, low frequency or mid-high frequency volume source and plane sound source, during building and acoustic field measurements.

PA700 based on class-D power amplifier technology, thus achieving a very small size and lightweight with a large output power, making it very suitable for field testing of building acoustic. The peak output power is up to 710 W with excellent THD+N and dynamic range. All connectors, controllers and displays are located on the front panel. The power amplifier can therefore be placed on the ground or in any other field for easy access.

PA700 has digital volume control, which can adjust the output amplitude according to dB level (it can display the maximum output power at this time). It also retains the continuous volume adjustment knob for fine tuning. PA700 also has a built-in white noise and pink noise generator, and a Bluetooth audio receiver can play the stored audio files of mobile devices. Built-in noise signal and Bluetooth audio signal can be line out to other devices. PA700 is also supplied with wireless remote control, which can turn on / off the output of power amplifier even across building floor.

Specifications

Architecture of Power Amplifier	Class-D
Rated Output Power (Continuous, 25°C)	270 W _{RMS} (4 Ω /8 Ω)
Peak Output Power ^{1,3}	710 W _{RMS} (4 Ω), 360 W _{RMS} (8 Ω) (1 kHz, THD+N \leq 1 %. short duration: duty cycle 1/5, on time 300 s. supply by 230 VAC / 50 Hz)
Maximum Output Voltage ³	75 V _{Peak} (4 Ω /8 Ω)
Maximum Output Current	30 A
Minimum Load	2.5 Ω



Maximum Capacitive Loading	220 nF	
Output Impedance ² (Typ.)	0.006 Ω (1 kHz), ≤0.4 Ω (20 Hz~20 kHz)	
Output Idle Noise ^{3, 4} (Typ.)	22 Hz~20 kHz, Gain=0 dB: 169 uV _{RMS} (4 Ω), 170 uV _{RMS} (8 Ω)	A-weighting, Gain=0 dB: 120 uV _{RMS} (4 Ω), 121 uV _{RMS} (8 Ω)
Frequency Response ³ (Typ.)	22 Hz~20 kHz, Gain=0 dB: 169 uV _{RMS} (4 Ω), 170 uV _{RMS} (8 Ω) +0.2 dB~-0.7 dB (4 Ω), +0.2 dB~-0.8 dB (8 Ω) (20 Hz~20 kHz)	
Dynamic Range ³ (Typ.)	22 Hz~20 kHz, 1 kHz: 109.9 dB (4 Ω), 109.9 dB (8 Ω)	A-weighting, 1 kHz: 112.9 dB (4 Ω), 112.8 dB (8 Ω)
THD+N ³ (Typ.) (@ 1 kHz)	1 W _{RMS}	0.033 % (4 Ω), 0.032 % (8 Ω)
	50 % power	0.036 % (4 Ω), 0.024 % (8 Ω)
	85 % power	0.050 % (4 Ω), 0.033 % (8 Ω)
	95 % power	0.490 % (4 Ω), 0.494 % (8 Ω)
Output Drive Mode	BTL	
Output Connector	speakON socket and 4 mm banana socket	
Maximum Input Voltage (Input Sensitivity)	1.0 V _{RMS}	
Input Impedance (Typ.)	≥39 kΩ (20 Hz~20 kHz)	
Input Connector	XLR (balanced) and BNC (unbalanced)	
Volume Control (Input Attenuator)	Analog: -∞~0 dB (continuous). Digital: 0 dB~-25 dB (1 dB/step), -27 dB, -30 dB, -39 dB and -Inf, total 30 steps	
Built-in Noise Generator	White Noise (20 Hz~20 kHz: ±1 dB, CF=2.5), pink Noise (20 Hz~20 kHz / ±1.5 dB, CF=4.6), period Time: 120 s	
Bluetooth Audio	Bluetooth v4.0, 2.4 GHz, AAC、MP3、SBC、APTX decoder	
Switching Frequency Range (Amplifier)	90 kHz~560 kHz	
Total Power Efficiency	74 %~84 % (100 W _{RMS} ~700 W _{RMS})	
Limiter and Overload Indicator	Built-in voltage limiter with clip indicator on when maximum output amplitude was reached.	
Remote Control ⁵	LoRa [®] spread spectrum 433 MHz wireless remote control, transmitting range 100 m (≤10 mW) and cross two layer floors at least. (915 MHz wireless remote control is optional, must consult before ordering.)	
Protection	Overload, over-current, loop saturation, thermal and high-frequency protection	
Cooling	Fan forced cooling (Automatic fan control based on output power)	
Power Supply	100-240 VAC 50-60 Hz, 900 W Max, IEC Type C13 connector	
Fuse	T6AL 250V (5 mm x 20 mm)	
Firmware Update	Update firmware via USB port	
Operation Environment	-10 °C~50 °C, 0 %RH~95 %RH	
Dimensions (mm)	W284 x H90 x D248	
Shipping Case Dimension (mm)	W428 x H153 x D350	
Weight	3.0 kg (power amplifier only)	

Note 1: Contact manufacturer for the peak output power operating time of other supply voltage.

Note 2: Measured directly at the terminals on the PCB.

Note 3: Measured by AUX-0025 filter and dScope Series III analyzer with AES17 20 kHz filter.

Note 4: Measured by connected a 600 Ω external terminal at input.

Note 5: The remote control transmitting range and floor across tests were carried out using 433 MHz remote control in commercial / residential buildings of ordinary specifications.



Front Panel



Block Diagram

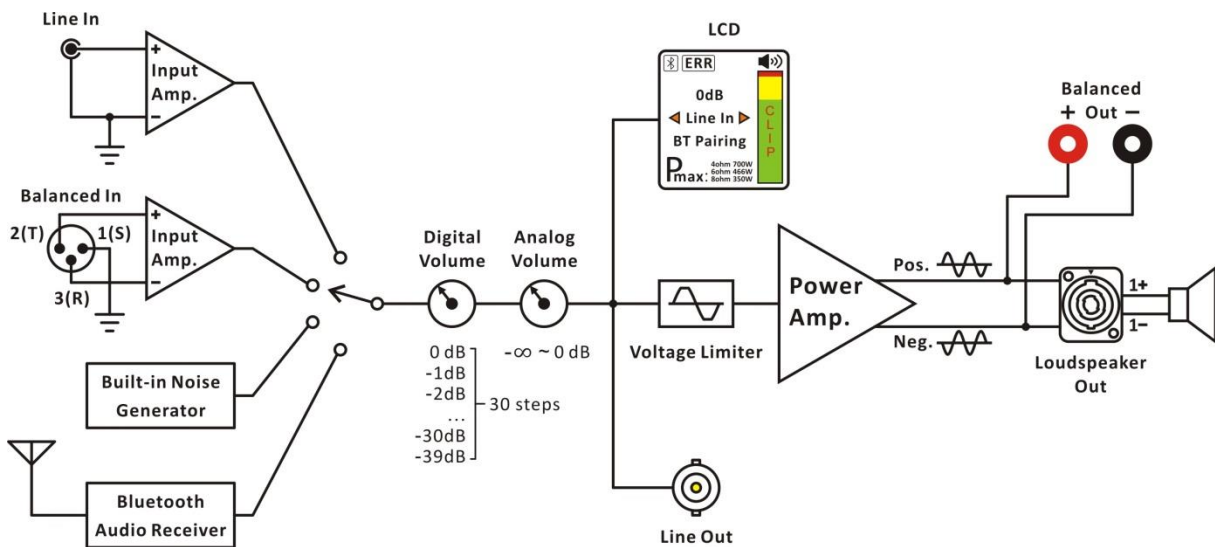

BSWA Technology Co., Ltd. Room 1003, North Ring Center, No.18 Yumin Road, Xicheng District, Beijing 100029, China • Tel: 86-10-5128 5118 • Fax: 86-10-8225 1626 • E-mail: info@bswa.com.cn • URL: www.bswa-tech.com
Copyright © BSWA Technology Co., Ltd. • Content is subject to change without notice.

